



IVC, IVCT

Wafer Type Swing Check Valve



Intervalve[®] check valve models IVC and IVCT are primarily single plate swing check valve with a short pattern wafer body conforming to the API 6D and ANSI B16.10 face to face dimensions. The valve has a simple but robust construction with reliability. The low inertia disc design enables the valve to open or close with a very low differential pressure which make them ideal for services operating under low differential pressures. The pressure drop across the valve in fully open condition is relatively low and makes them ideal for pump discharge duties. The eccentric disc shaft in combination with the disc seat guarantees a positive shut off of the returning media.

The short face to face dimensions and low weight allows a simple space saving installation between the mating companion flanges. The

valves are suitable for mounting between weld neck or slip on type companion flanges of different standards. The need for flange gaskets during installation is totally eliminated in the case of IVC model due to the in-built face sealing 'O' rings provided on the sealing face. Gaskets are recommended while installing IVCT model valves.

Conformity to codes and standards :

Valve testing	:	API 598 / ANSI B 16
Design & face to face dimensions	:	API 6D / ANSI B 16
Flange standard conformity	:	ANSI 150, DIN PN 10 & PN 16, BS 10 Table D & E

Technical specifications :

1. Valve type	:	Self acting non-return valve.
2. Description	:	Single plate wafer type swing check valve.
3. Body type	:	Short pattern wafer type
4. Disc type	:	With integral hinge pin
5. Model nomenclature	:	IVC-check valve with rubber O-ring seat and face sealing IVCT-check valve with PTFE seat and serrated contact faces
6. Size range	:	25 NB to 600 NB
7. Pressure rating	:	PN 16 (max)
8. Operating temperature range	:	-25 C to 200 C (depending on MOC)
9. Seat leakage	:	Zero leak / tight shut off
10. Standard Material of Construction (MOC)	:	
Body	:	SGI /WCB/ CF8/ CF8M/CS-IS 2062
Disc	:	SGI /WCB/CF8/CF8M
Seat	:	EPDM / Viton/ Nitrile/ Neoprene / Hypalon – for IVC PTFE or GFT –for IVCT



DIMENSIONS (in mm.)

Valve size	A	B	C				
			PN 10	PN 16	BS10D	BS10E	ANSI#150
25	14	16	72	72	69	69	64
40	22	19	93	93	86	86	86
50	30	19	108	108	97	97	104
65	40	19	128	128	110	110	123
80	52	19	143	143	129	129	136
100	71	19	163	163	161	161	174
125	93	19	193	193	193	193	196
150	114	19	219	219	218	215	221

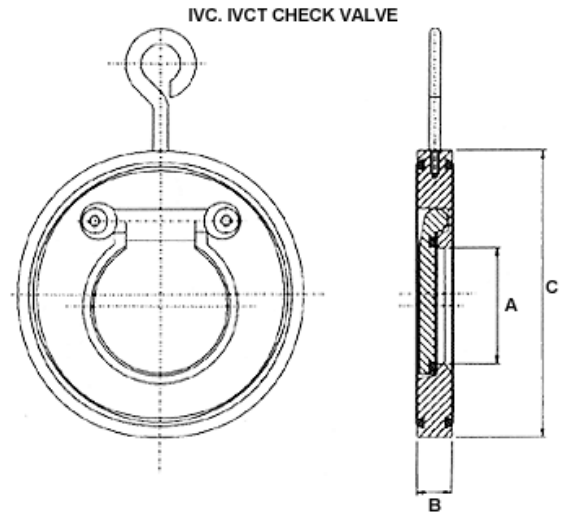

DIMENSIONS (in mm.)

Valve size	A	B	C				
			PN 10	PN 16	BS10D	BS10E	ANSI#150
200	157	28.5	274	274	274	272	278
250	195	28.5	329	329	335	335	339
300	230	38.0	379	385	385	383	409
350	270	44.5	438	444	446	446	449
400	310	51.0	489	496	496	496	512
450	360	60.5	538	555	559	559	545
500	406	63.5	593	616	616	616	605
600	490	70.0	695	733	727	724	714

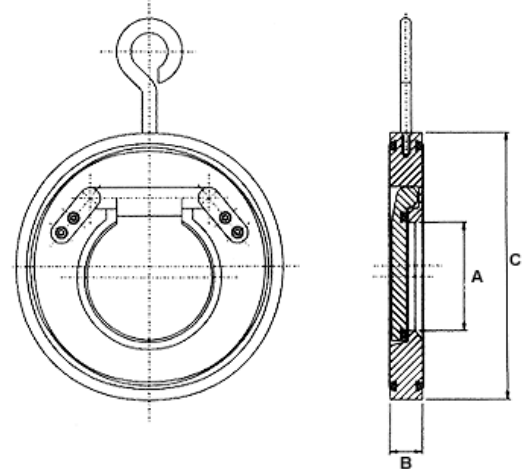

Key features :

- ❑ Very low face to face dimensions hence space required for mounting is less than 10% of that conventional valves.
- ❑ Very low weight-total weight is only approximately 1/6 the weight of a conventional check valve.
- ❑ Short wafer body enables mounting the valve with shorter length fasteners of lesser number compared to flanged swing check valve. Approximately 50% saving in cost of fasteners.
- ❑ Considerable secondary advantages resulting in substantial savings in handling, packing, transportation, installation and maintenance.
- ❑ Saving in terms of overall length required for piping.
- ❑ Tightening torque to be applied on the companion flange bolting is lower due to face sealing O-rings.
- ❑ Practically maintenance free due to fewer number of parts and simple construction.
- ❑ Self centering in pipeline due to controlled outside diameter, enables easy installation.



INTERVALVE[®] (INDIA) LTD.



212/2, HADAPSAR, OFF SOLI POONAWALLA ROAD, PUNE – 411028. INDIA

TEL: 91-20-26993900, 26993904 FAX : 91-20-26993921

<http://www.poonawallagroup.com> E-mail: intervalve@poonawallagroup.com

Specifications & dimensions are subject to change without prior notice.